

PRELIMINARY SPEC



ATTENTION
OBSERVE PRECAUTIONS
FOR HANDLING
ELECTROSTATIC
DISCHARGE
SENSITIVE

Part Number: AAD1-9090BRGC-01/3

Blue
Reddish-Orange
Green

Features

- SUPER HIGH FLUX OUTPUT AND HIGH LUMINANCE.
- DESIGNED FOR HIGH CURRENT OPERATION.
- LOW THERMAL RESISTANCE.
- LOW VOLTAGE DC OPERATED.
- SUPERIOR ESD PROTECTION.
- NOT REFLOW COMPATIBLE.
- PACKAGE: 500PCS/REEL.
- THE COMPONENT IS INTERNALLY PROTECTED WITH SILICONE GEL.
- RoHS COMPLIANT.



Application Note

Static electricity and surge damage the LEDs.

It is recommended to use a wrist band or anti-electrostatic glove when handling the LEDs.

All devices, equipment and machinery must be electrically grounded.

Applications

- traffic signaling.
- backlighting (illuminated advertising , general lighting).
- interior and exterior automotive lighting.
- substitution of micro incandescent lamps.
- portable light source (e.g. bicycle flashlight).
- signal and symbol luminaire for orientation.
- marker lights (e.g. steps, exit ways, etc).
- decorative and entertainment lighting.
- indoor and outdoor commercial and residential architectural lighting.

Package Dimensions

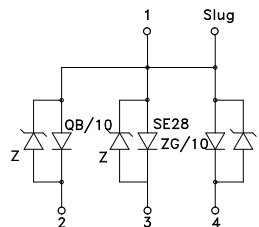
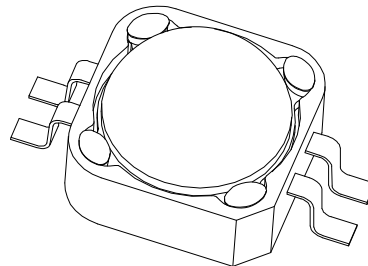
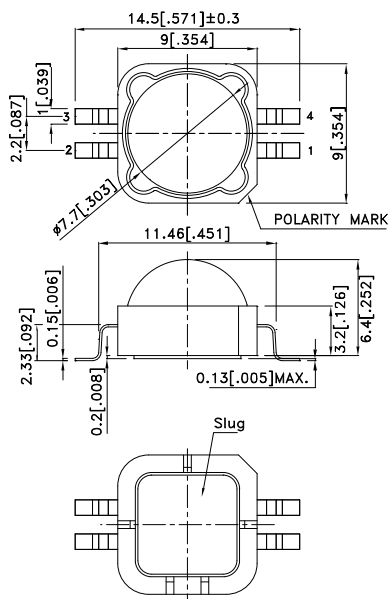

Notes:

1. All dimensions are in millimeters (inches).
2. Tolerance is $\pm 0.25(0.01)$ unless otherwise noted.
3. Specifications are subject to change without notice.
4. The device has a single mounting surface. The device must be mounted according to the specifications.



Selection Guide

Part No.	Dice	Lens Type	luminous Intensity [2] Iv(cd)@ 350mA		Φv (lm) [2] @ 350mA		Viewing Angle [1]
			Min.	Typ.	Min.	Typ.	2θ1/2
AAD1-9090BRGC-01/3	BLUE (InGaAlN)	WATER CLEAR	2.5	3.5	15	20	135°
	Reddish-Orange (InGaAlP)		6.7	8	25	30	
	Green (AlInGaN)		10	16	32	50	

Notes:

- 01/2 is the angle from optical centerline where the luminous intensity is 1/2 the optical centerline value.
- Luminous intensity / luminous Flux: +/-15%.

Absolute Maximum Ratings at TA=25°C

Parameter	Symbol	Device	Value	Unit
Power dissipation	Pt	Blue	1.25	W
		Reddish-Orange	1.05	
		Green	1.33	
Junction temperature	Tj	Blue	110	°C
		Reddish-Orange	110	
		Green	110	
Operating Temperature	Top	Blue	-40 To +100	°C
		Reddish-Orange		
		Green		
Storage Temperature	Tstg	Blue	-40 To +100	°C
		Reddish-Orange		
		Green		
DC Forward Current [1]	If	Blue	350	mA
		Reddish-Orange	350	
		Green	350	
Peak Forward Current [2]	IfM	Blue	500	mA
		Reddish-Orange	500	
		Green	500	
Thermal resistance [1]	Rth j-slug	Blue	9	°C/W
		Reddish-Orange	12	
		Green	9	
Electrostatic Discharge Threshold (HBM)		Blue	8000	V
		Reddish-Orange		
		Green		
Iron Soldering [3]		Blue	350°C For 3 Seconds	
		Reddish-Orange		
		Green		

Notes:

- Metal Core PCB is mounted on the heat Fins.
- 1/10 Duty Cycle, 0.1ms Pulse Width.
- 1.29mm below package base.

Electrical / Optical Characteristics at TA=25°C

Parameter	Symbol	Device	Value			Unit
			Min.	Typ.	Max.	
Wavelength at peak emission IF=350mA	λ_{peak}	Blue		452		nm
		Reddish-Orange		640		
		Green		520		
Dominant Wavelength IF=350mA	λ_{dom} [1]	Blue		458		nm
		Reddish-Orange		625		
		Green		530		
Spectral bandwidth at 50% $\Phi_{REL MAX}$ IF=350mA	$\Delta\lambda$	Blue		20		nm
		Reddish-Orange		30		
		Green		35		
Forward Voltage IF=350mA	VF [2]	Blue	2.8	3.2	3.6	V
		Reddish-Orange	2.0	2.5	3.0	
		Green	2.7	3.3	3.8	
Temperature coefficient of λ_{peak} IF=350mA, -10°C ≤ T ≤ 100°C	TC λ_{peak}	Blue		0.2		nm/°C
		Reddish-Orange		0.12		
		Green		0.16		
Temperature coefficient of λ_{dom} IF=350mA, -10°C ≤ T ≤ 100°C	TC λ_{dom}	Blue		0.1		nm/°C
		Reddish-Orange		0.05		
		Green		0.14		
Temperature coefficient of VF IF=350mA, -10°C ≤ T ≤ 100°C	TCV	Blue		-3.2		mV/°C
		Reddish-Orange		-2.6		
		Green		-2.26		

Notes:

1. Wavelength: +/-1nm.
2. Forward Voltage: +/-0.1V.

Kingbright

AAD1-9090BRGC-01/3 Blue

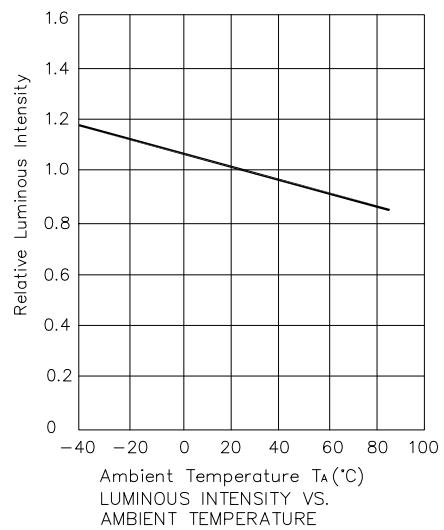
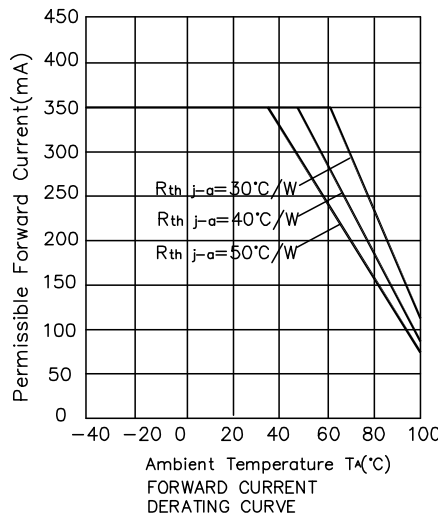
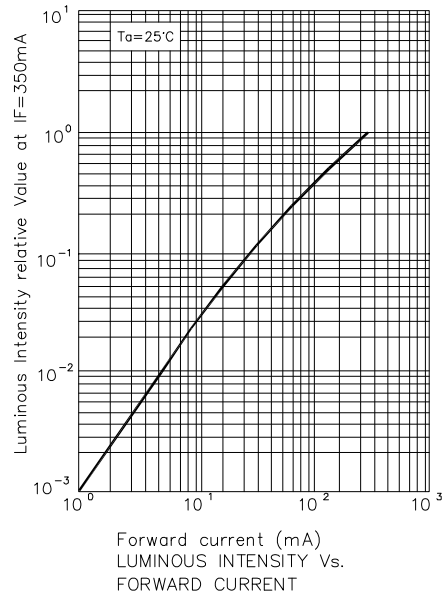
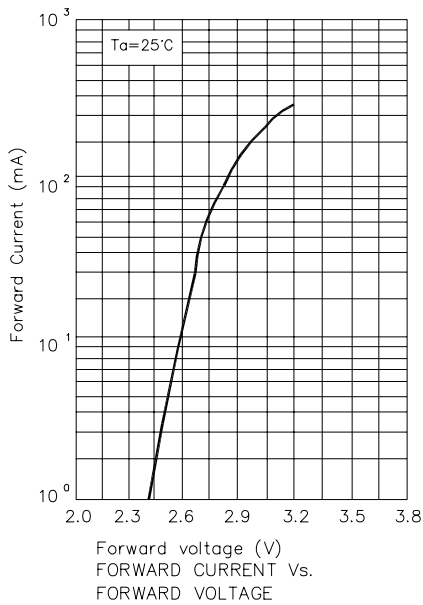
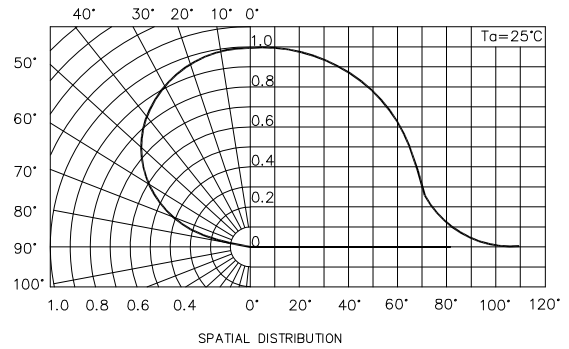
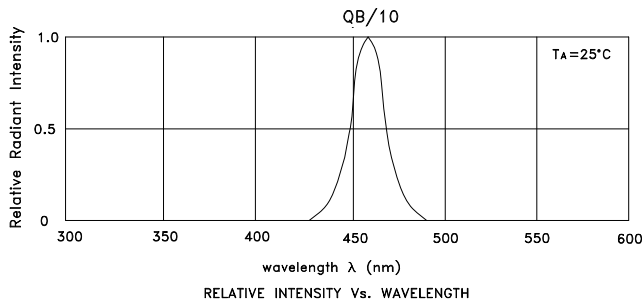

Reddish-Orange

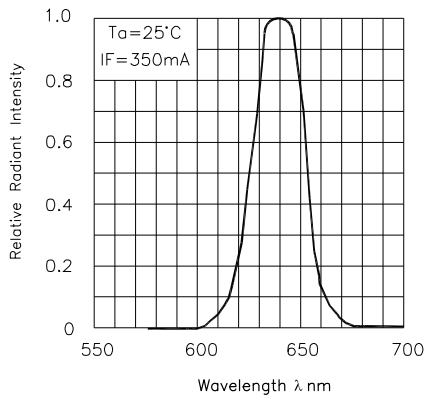

RELATIVE INTENSITY Vs. WAVELENGTH

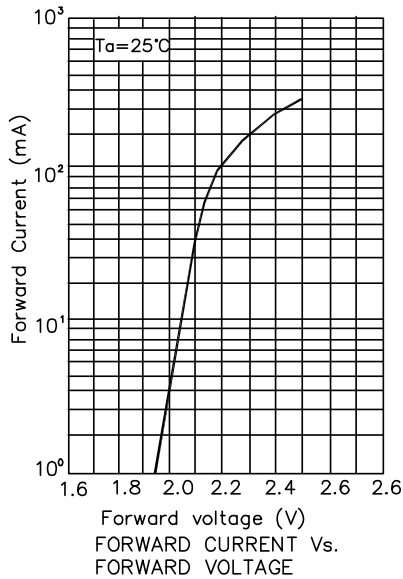
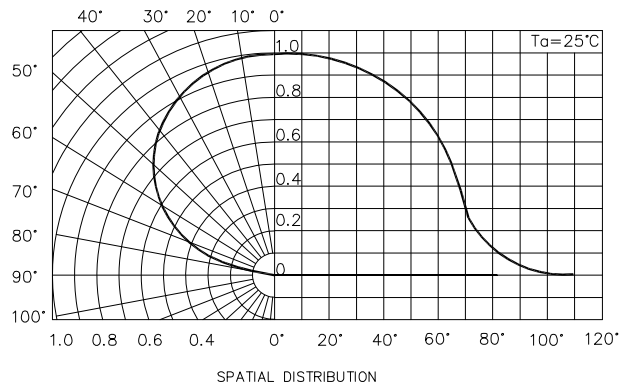

FORWARD CURRENT Vs. FORWARD VOLTAGE

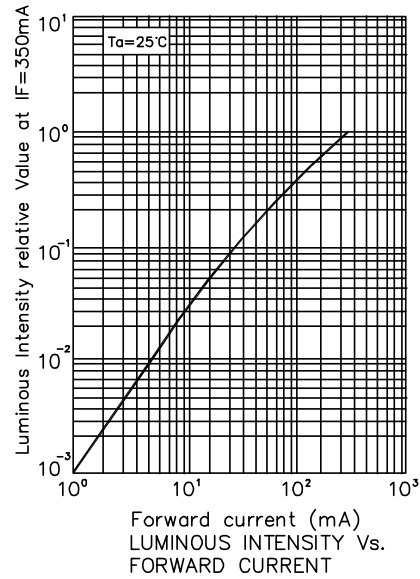

LUMINOUS INTENSITY Vs. FORWARD CURRENT

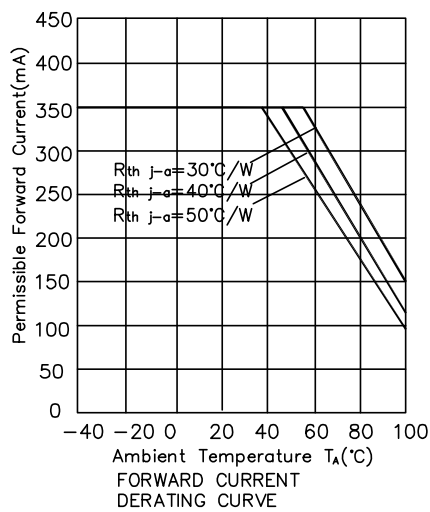

FORWARD CURRENT DERATING CURVE

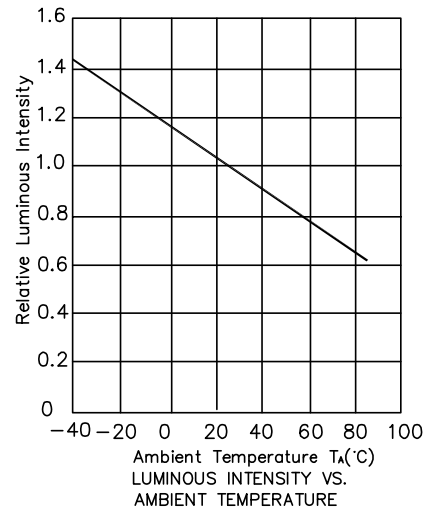

Kingbright

Green

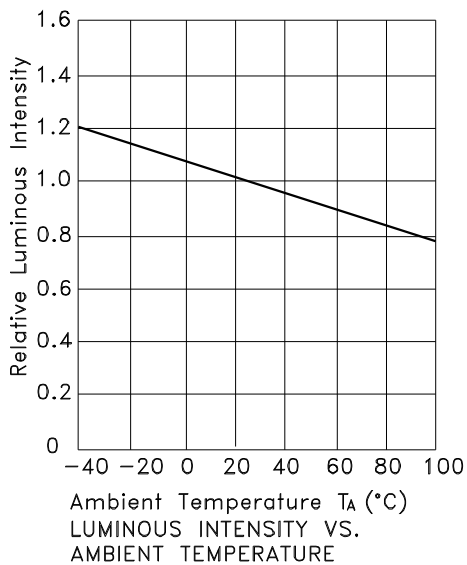
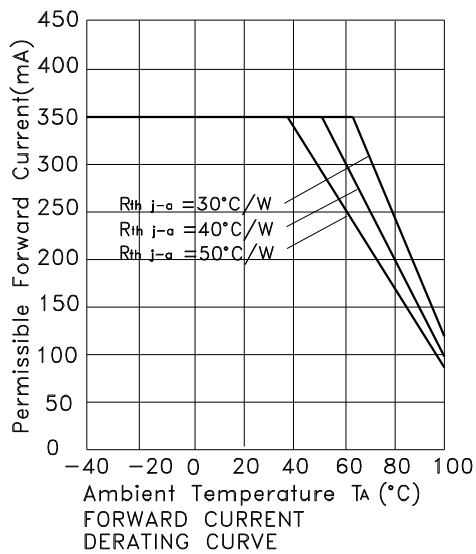
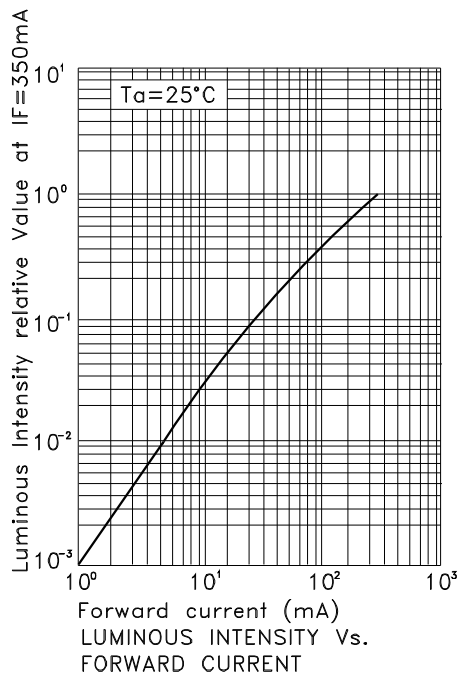
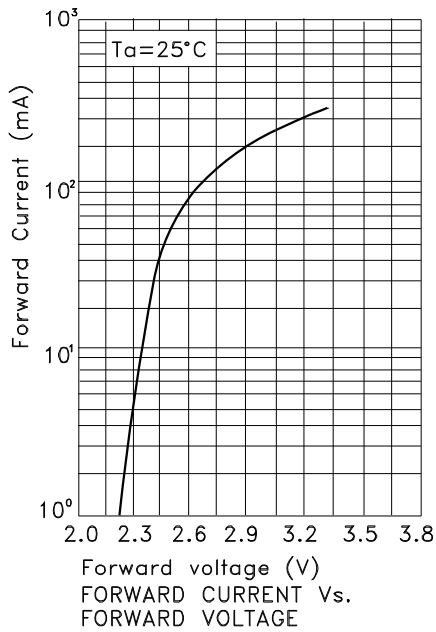
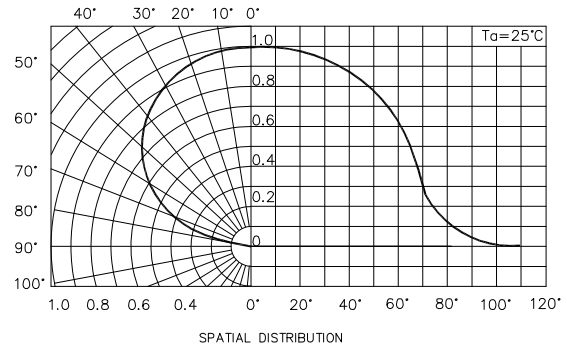
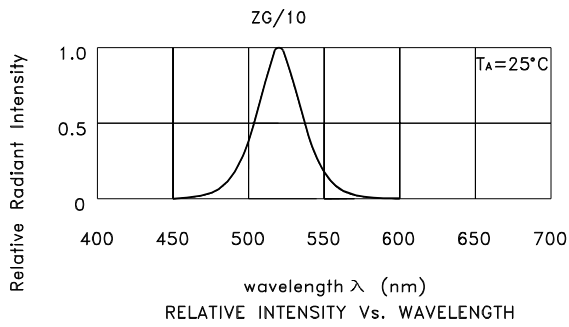

AAD1-9090BRGC-01/3
Recommended Soldering Pattern
 (Units : mm; Tolerance: ± 0.1)

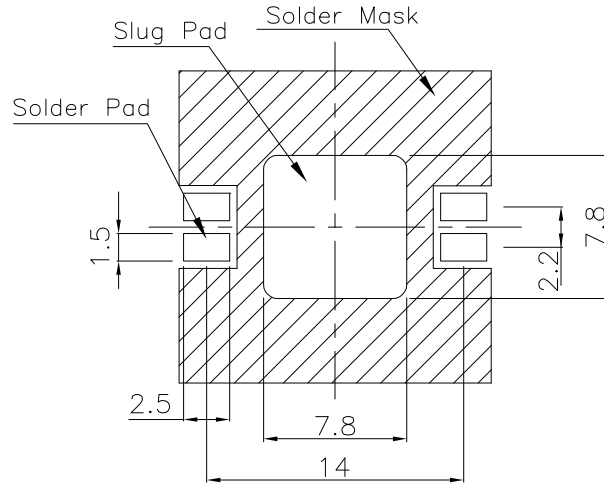

Tape Specifications
 (Units : mm)

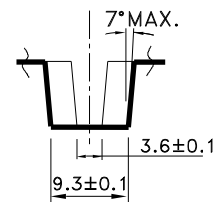
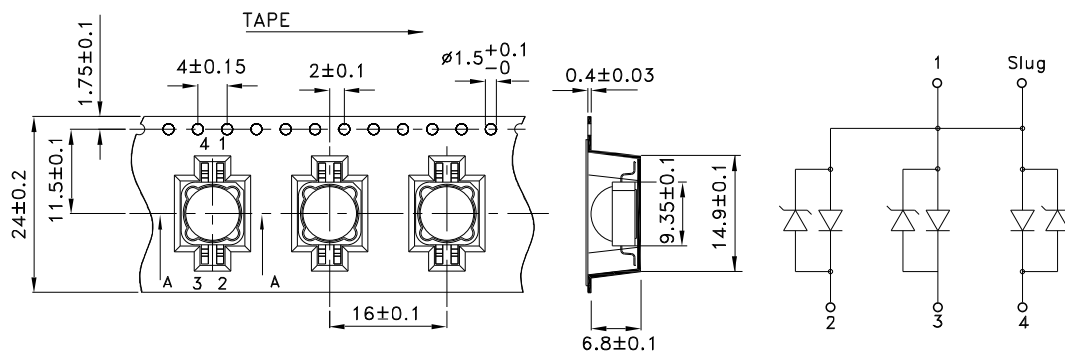

A-A SECTION

AAD1-9090BRGC-01/3 Recommended Solder Steps

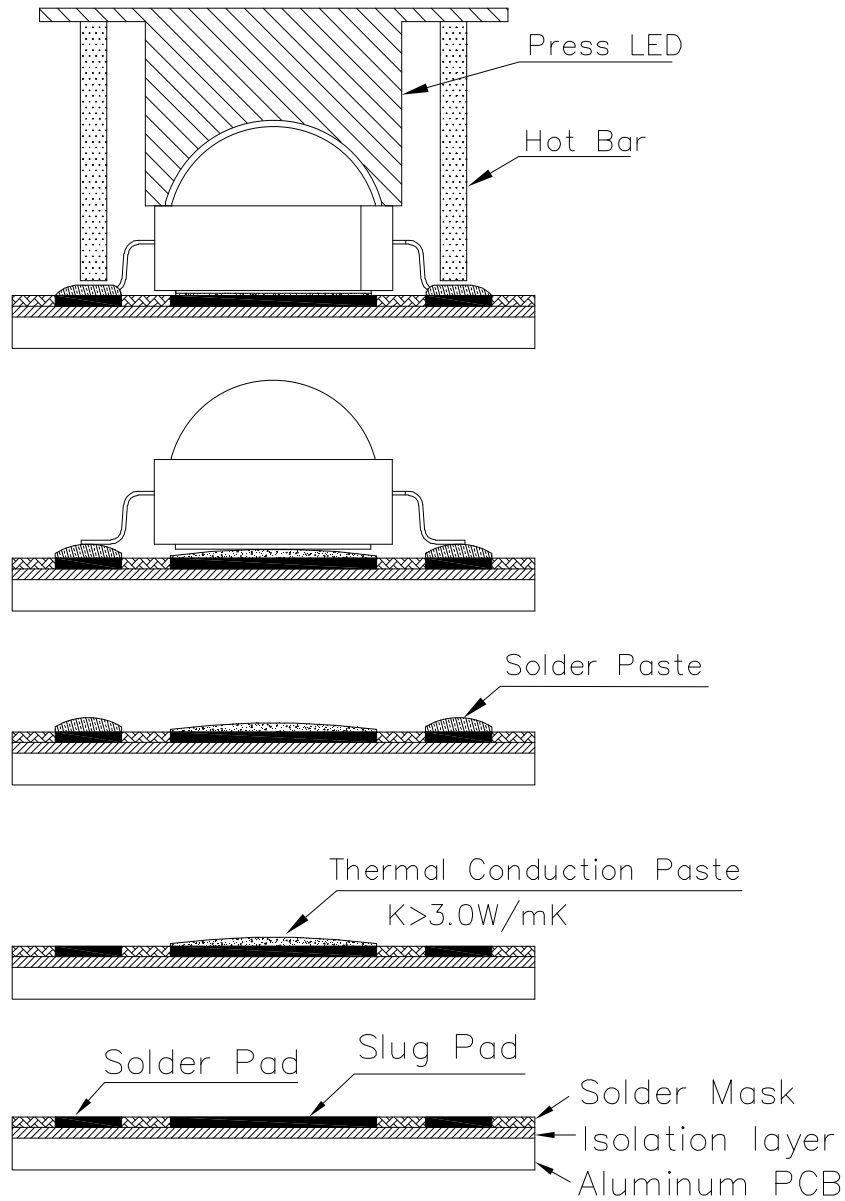

Kingbright

PACKING & LABEL SPECIFICATIONS

AAD1-9090BRGC-01/3

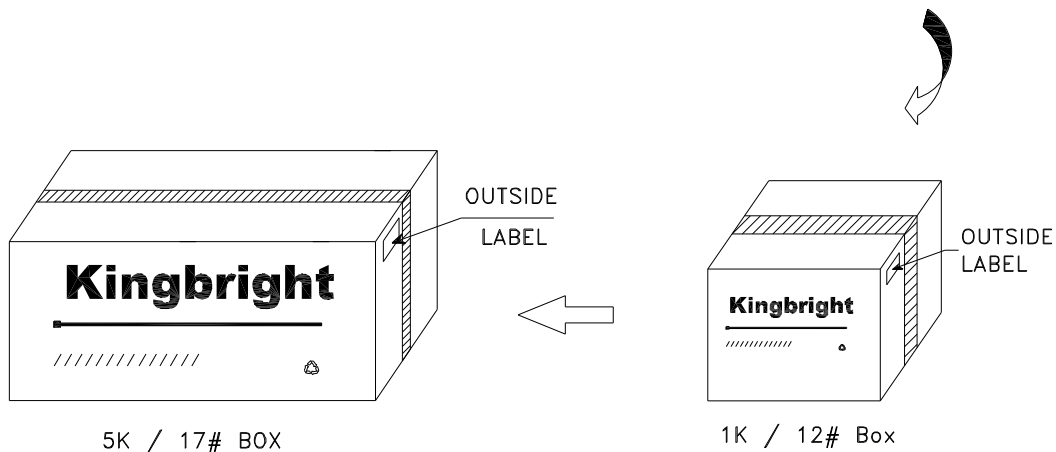
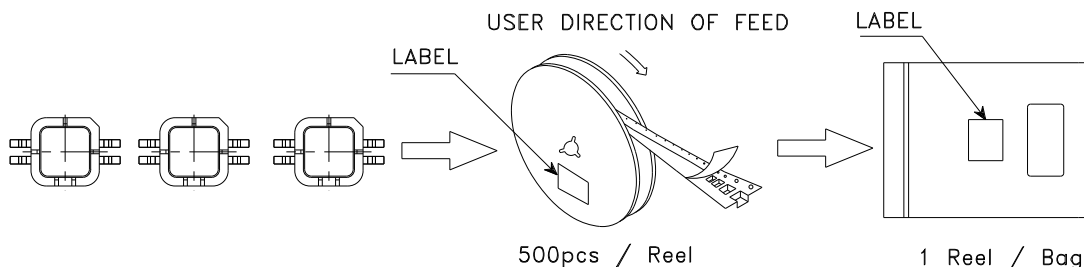

Kingbright	
P/NO: AAD1-9090xxx	
QTY: 500 pcs	Q.C. Q C XX XX XXXX PASSED
S/N: XXXX	
CODE: XXX	
LOT NO:	
 XXXXXXXXXXXXXXXXXXXXXXXXXXXX	
RoHS Compliant	